



Electric Pressure Control On-Off Deluge Valve

Model FP 400Y - 3DC

The BERMAD model 400Y-3DC is an elastomeric, hydraulic, line pressure operated deluge valve, designed specifically for advanced fire protection systems and the latest industry standards.

The 400Y-3DC is activated by a 3-way solenoid valve by which opening and closing of the deluge valve may be controlled remotely.

An integrated pressure control pilot ensures a precise and stable pre-set downstream water pressure.

The 400Y-3DC is ideal for open-nozzle systems with a high pressure water supply and is available with electric components to suit any hazardous location.

The optional valve position indicator can include a limit switch suitable for Fire & Gas monitoring systems.



(for Illustration Only)

Benefits and Features

- **Safety and reliability**
 - Time-proven, simple, fail-safe actuation
 - Single-piece, rugged, elastomeric diaphragm seal VRSD technology
 - Obstacle-free, uninterrupted flow path
 - No mechanical moving parts
 - Shuts off on remote command
 - Ensures precise, stable downstream water pressure
 - Valve position limit switches (optional)
- **Designed for fire protection**
 - Face-to-face length standardized to ISO 5752, EN 558-1
 - Meets the requirements of the industry standards
- **Quick and easy maintenance**
 - In-line serviceable
 - Fast and easy cover removal
 - Swivel mounted drain valves*

* for 3" valves and larger

Typical Applications

- Remote control water spray systems
- Foam applications
- Corrosive water supplies
- High pressure water supply

Approvals



UL-Listed
Special System Water Control
Valves, Deluge Type (VLFT)
Sizes 1½" - 16"



Det Norske Veritas
Type Approval



ABS
American Bureau of Shipping
Type Approval



Lloyd's Register
Type Approval

Additional Features

- Valve position limit switches
- Sea water compatibility
- Alarm pressure switch
- Drain valve/s inlet/outlet
- For "automatic activation" select BERMAD local or remote reset model

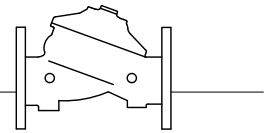

Operation

(for Illustration Only)

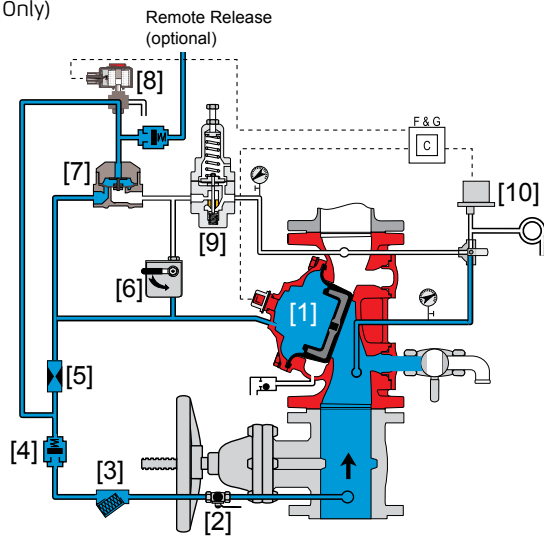

Valve Closed (normal conditions)

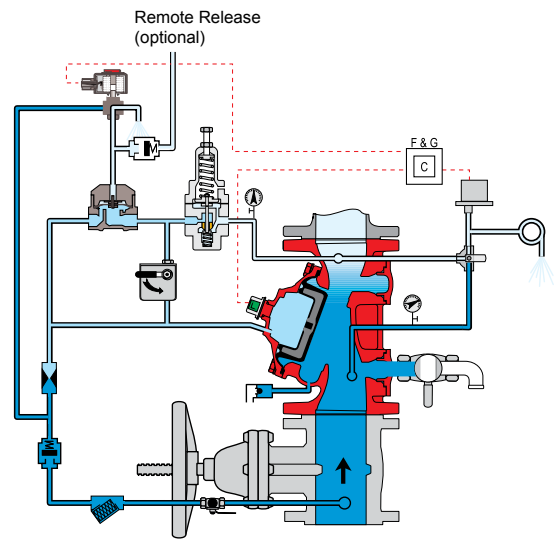

Valve Open (fire conditions)

The BERMAD model 400Y-3DC is held closed by water pressure in the control chamber [1]. Upon release of pressure from the control chamber, the valve opens.

Under NORMAL conditions, water pressure is supplied to the control chamber via the priming line [2] restriction orifice [5], and strainer [3], and is then trapped in the control chamber by a check valve [4], manual emergency release [6], and a relay valve (HRV) [7] that is held closed by hydraulic pressure supplied through a three-way solenoid valve [8]. The water pressure trapped in the main valve control chamber holds the diaphragm against the valve seat, sealing it drip-tight and keeping the system pipes dry.

Under FIRE conditions, water pressure is released from the control chamber, either with the manual emergency release, or by the HRV opening in response to either the solenoid valve being activated by the fire & gas control system [C] or the by remote release. This opens the 400Y-3DC deluge valve, allowing water to flow into the system piping and to the alarm device [10].

The pressure-control pilot valve [9] senses changes in outlet pressure and, modulates the main valve to maintain the set downstream pressure. When outlet pressure rises above the pre - set pressure value, the pilot valve throttles, enabling pressure to accumulate in the control chamber. This causes the main valve to close further and reduce outlet pressure, keeping the outlet pressure at the set value. When outlet pressure falls, the pilot valve opens wider, releasing pressure from the control chamber. This causes the main valve to open wider and increase outlet pressure.

System P&ID

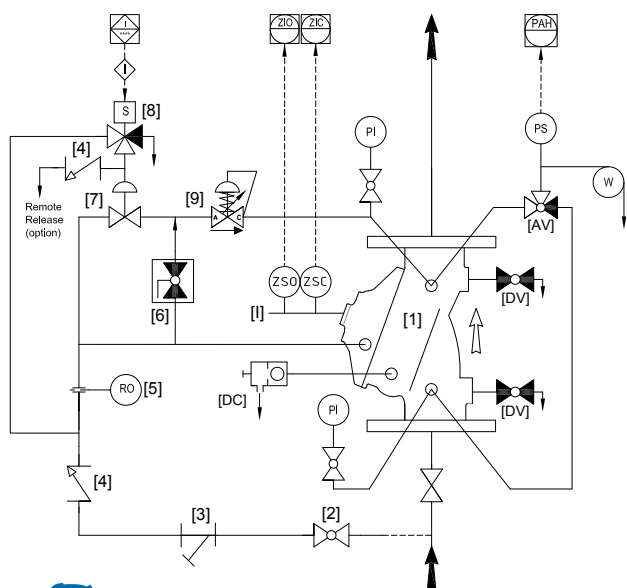

Components

- 1 BERMAD 400Y Deluge Valve
- 2 Priming Ball Valve
- 3 Priming Strainer
- 4 Check valve
- 5 Restriction Orifice
- 6 Manual Emergency Release
- 7 HRV-2 Hydraulic Relay Valve
- 8 3-Way Solenoid Valve
- 9 Pressure Control Pilot Valve

Optional System Items*

- PI Pressure Gauge
- I Valve Position Indicator
- DC Drip Check
- AV 3-Way Alarm Valve
- DV Drain Valve
- PS Pressure Switch
- ZS Limit Switch Assembly
- W Water Motor Alarm

*See also Factory Fitted Options under the *Valve Code Designations* on the last page



System Installation

A typical installation of the BERMAD model 400Y-3DC features actuation via a hydraulic relay valve and three-way solenoid valve, triggered by a signal from a fire & gas control system or an on-site emergency pushbutton. When open, and fitted with a limit switch the valve can send a feedback signal to a remote valve position monitoring system.

A pressure control pilot valve integrated in the control trim ensures a precise and stable pre-set downstream water pressure.

Optional System Items

(Click on item for link to product page)



[Limit switch](#)



[Water Motor Alarm](#)



[Pressure Switch](#)



[Pressure Gauges](#)



[Strainer](#)

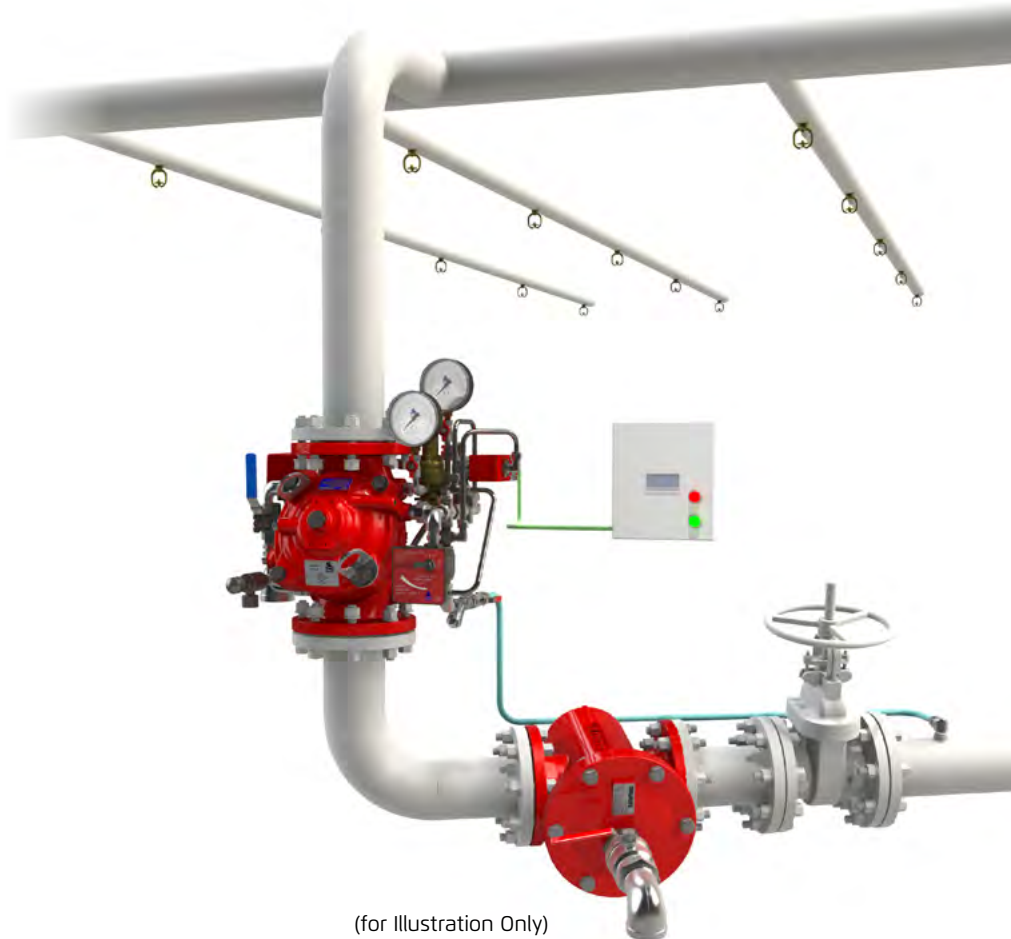

Suggested Specifications

The deluge valve shall be UL listed, 25 bar/365 psi rated, elastomeric-type, with a straight-through, Y-type body.

The valve shall have an unobstructed flow path, with no stem guide or supporting ribs.

Valve actuation shall be accomplished by a single-piece rolling diaphragm, bonded with a rugged radial seal disk. The diaphragm assembly shall be the only moving part.

The deluge valve shall include a relay pilot valve, a 3-Way solenoid valve approved for 25 bar (365 psi) working pressure with a tolerance of 35% below the rated voltage.

The trim shall include a pressure control pilot valve, a Y-type strainer, a ball drain valve, an automatic drip-check with manual override, 4-inch pressure gauges and a manual emergency release housed in a stainless steel box. The valve drain socket shall be flanged and have a 360-degree swivel.

The valve shall be equipped with two limit switches.

Removing the valve cover for inspection and maintenance shall be in-line and not require removal of the control trim, or the valve from the pipeline.

The deluge valve and its entire control trim shall be supplied pre-assembled and hydraulically tested by a factory certified to ISO 9000 and 9001 standards.

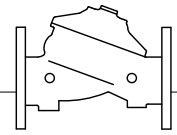

Technical Data

Available Sizes (inch)

- Flanged - 1½, 2, 3, 4, 6, 8, 10, 12, 14 & 16"
- Grooved - 1½, 2, 3, 4, 6 & 8"
- Threaded - 1½ & 2"

Pressure Rating

- ANSI#150 - 17.2 bar / 250 psi
- ANSI#300 - 1½" to 10" 25 bar / 365 psi
12" to 16" 20 bar / 300 psi
- Grooved - 25 bar / 365 psi
- Threaded - 25 bar / 365 psi
- Standard setting range*: 4 - 12 bar (60 - 175 psi)

*For other setting ranges consult BERMAD

Elastomer

- HTNR - Fabric Reinforced High Temperature Compound - [See engineering data](#)

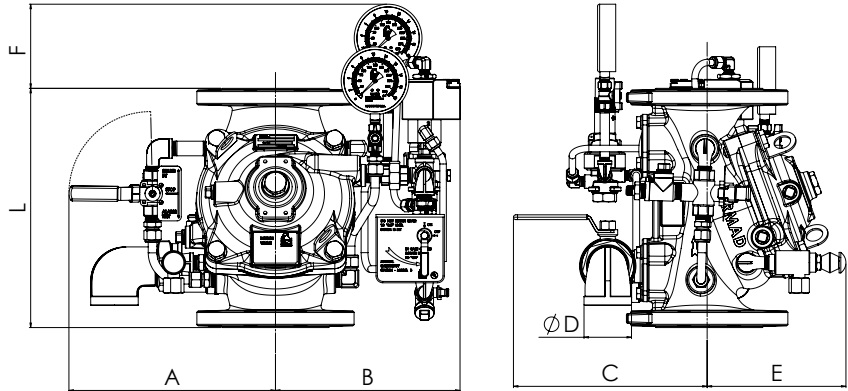

Valve Size	1½" DN40		2" DN50		3" DN80		4" DN100		6" DN150		8" DN200		10" DN250		12" DN300		14" DN350		16" DN400	
	mm	in	mm	in	mm	in	mm	in	mm	in	mm	in	mm	in	mm	in	mm	in	mm	in
⁽¹⁾ LANSI #150	230	9.1	230	9.1	310	12.2	350	13.8	480	18.9	600	23.6	730	28.7	850	33.5	980	38.6	1100	43.3
⁽²⁾ ANSI #300	230	9.1	235	9.3	326	12.8	368	14.5	506	19.9	626	24.7	730	28.8	850	33.5	980	38.6	1100	43.3
A	202	8.0	202	8.0	262	10.3	270	10.6	323	12.7	353	13.9	353	13.9	466	18.3	466	18.3	466	18.3
B	185	7.3	185	7.3	243	9.6	253	10.0	308	12.1	336	13.2	336	13.2	449	17.7	449	17.7	449	17.7
C	241	9.5	241	9.5	274	10.8	290	11.4	305	12.0	320	12.6	320	12.6	383	15.1	383	15.1	408	16.1
ØD	¾"		¾"		1½"		2"		2"		2"		2"		2"		2"		2"	
E	120	4.7	120	4.7	146	5.7	158	6.2	228	9.0	295	11.6	295	11.6	-276	-10.9	441	17.4	415	16.3
F	98	3.9	98	3.9	88	3.5	75	3.0	27	1.0	2	0.1	-	-	-	-	-	-	-	-
⁽³⁾ Kv / Cv	68 / 79		80 / 92		190 / 219		345 / 398		790 / 912		1160 / 1340		1355 / 1652		2600 / 3040		2950 / 3450		3254 / 3801	
⁽⁴⁾ Leq: m / ft	2 / 7		6 / 18		8 / 25		9 / 31		15 / 49		28 / 92		64 / 209		46 / 149		56 / 184		90 / 295	
Kg / lb (ANSI # 150)	18 / 40		20 / 43		34 / 76		44 / 98		88 / 193		151 / 332		181 / 398		324 / 713		357 / 785		403 / 887	
Kg / lb (ANSI # 300)	20 / 45		22 / 48		35 / 77		51 / 113		108 / 238		171 / 376		217 / 477		364 / 801		429 / 944		523 / 1151	

NOTES: ⁽¹⁾ Refers to the length dimensions for Raised Face ANSI #150, ISO 16 Flanged, Threaded and Grooved valves

⁽²⁾ Refers to the length dimensions for Raised Face ANSI #300 and ISO 25 Flanged valves

⁽³⁾ Flow coefficients apply to a fully opened valve

⁽⁴⁾ Leq (Equivalent Pipe Length) refers to turbulent flow in new steel pipe schedule 40 for a fully opened valve, values given for general consideration only

⁽⁵⁾ Dimensions for the trim envelope may vary with specific component positioning

Valve Code Designations

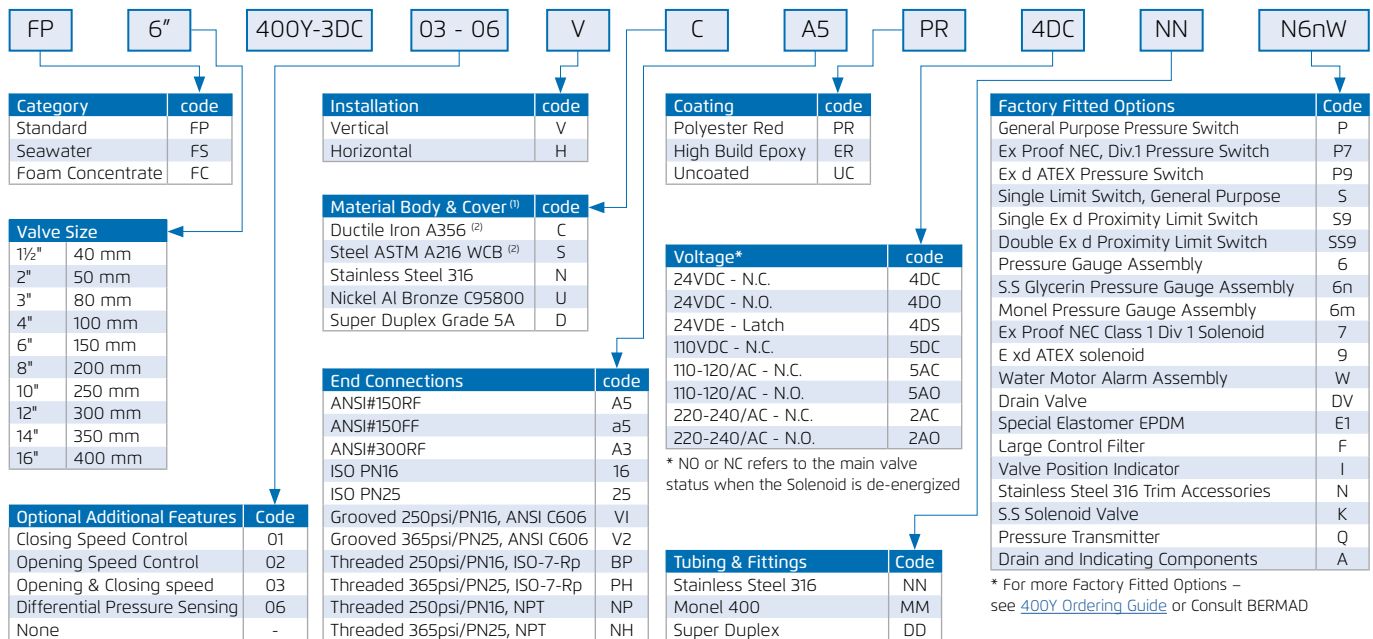

Notes: ⁽¹⁾ Other materials available see [400Y Engineering](#)

⁽²⁾ Coated internally and externally

