

## Pressure Reducing Valve

### Model 42T

The BERMAD model 42T is an elastomeric, line pressure driven pilot operated pressure control valve.

Designed specifically for advanced fire protection systems and the latest industry standards.

The 42T reduces high upstream pressure to a precise, preset, stable downstream pressure.

Due to its exceptional reliability and low head loss the 42T is ideal for control of fire pump discharge.

It is also well-suited to prevent over-pressure in sprinklers, hose stations, and other discharge devices.

As an option the 42T can be fitted with a valve position indicator that can include a limit switch suitable for Fire & Gas monitoring systems.

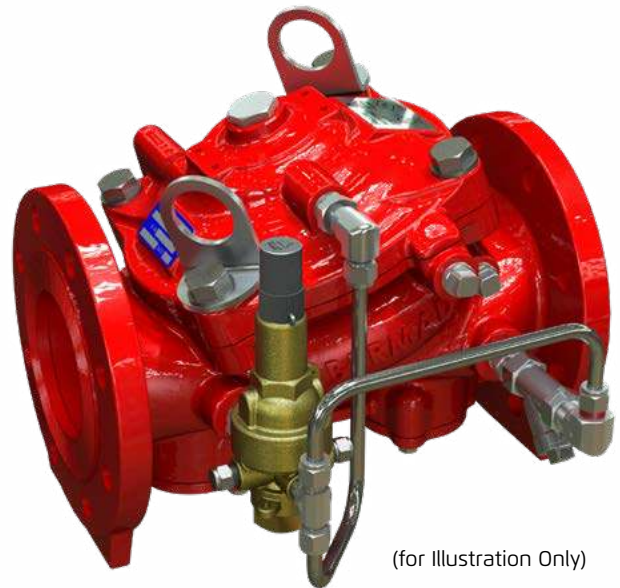

(for Illustration Only)

### Benefits and Features

- **Safety and reliability**
  - Time-proven, simple, fail-safe actuation
  - Single piece, rugged, elastomeric diaphragm seal - VRSD technology
  - Obstacle-free, uninterrupted flow path
  - Suitable for pump discharge control, due to low headloss
  - No mechanical moving parts
- **High performance**
  - Fast, smooth stabilizing response to pressure fluctuations
  - Very high flow efficiency
  - Straight through Y - type body
  - Approved for PN25/365 psi
- **Specifically-designed for fire protection**
  - Face-to-face length standardized to ISO 5752 EN 558-1
  - Accurate and stabilizing pressure control
  - Meets the requirements of industry standards
- **Quick and easy maintenance**
  - In-line serviceable
  - Fast and easy cover removal

### Typical Applications

- Sprinkler feed systems
- Fire pump discharge control
- Hose station supply
- Fire hydrant supply
- Foam systems
- Zonal pressure control

### Approvals



UL-Listed  
Special System Water Control Valves, Pressure Reducing (VLMT)  
Sizes 1½" - 16"



FM Approved  
Pressure Reducing Valves  
Sizes 1½" - 10"



Det Norske Veritas  
(Type Approval)



ABS  
American Bureau of Shipping  
Type Approval



Lloyd's Register  
Type Approval

### Additional Features

- Sea water compatibility
- Large control filter
- Integrated downstream relief valve
- Position limit switches

# BERMAD Fire Protection

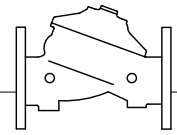

400Y Series

Model FP 400Y - 42T

## Operation

(for Illustration Only)

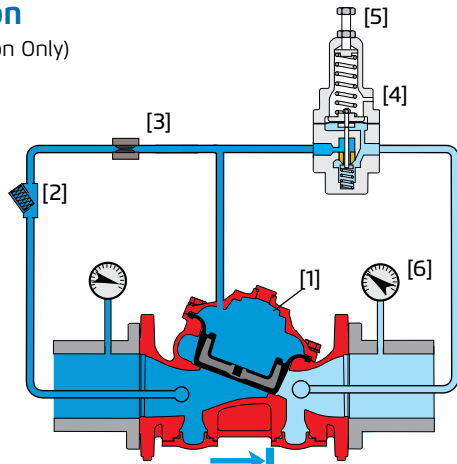

Valve Closed (non-flow conditions)

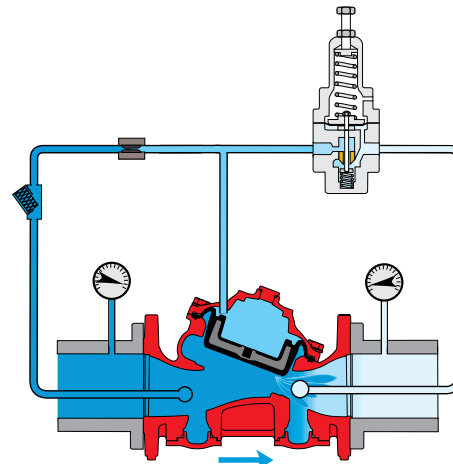

Valve Open (flow condition)

The BERMAD Model 42T pressure control valve, reduces water pressure automatically and accurately from a high inlet pressure to a lower, preset outlet pressure. The outlet set pressure can be adjusted by way of the pilot adjusting screw [5]. The valve operates under both flow and static conditions. The pressure-reducing pilot valve [4] senses changes in outlet pressure [6] and modulates the control valve to maintain the preset outlet pressure. When outlet pressure rises above the preset pressure, the pilot valve throttles, enabling pressure to accumulate in the control chamber [1], this causes the control valve to close further and reduce outlet pressure. When outlet pressure falls, the pilot valve opens wider, releasing pressure from the control chamber. This causes the control valve to open wider and increase outlet pressure. An integral restrictor [3] controls the valve's closing speed. For valve sizes 12, 14 & 16" an adjustable needle valve is provided.

## System P&ID

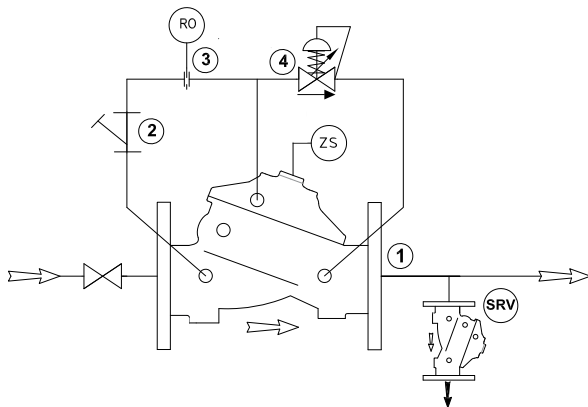

### Components

- 1 BERMAD 400Y Water Control Valve
- 2 Y Strainer
- 3 Restriction Orifice
- 4 Pressure Reducing Pilot Valve

### Optional System Items

- ZS Limit Switch Assembly
- SRV BERMAD 43T Pressure Relief Valve
- I Visual Indicator

See also Factory Fitted Options under the Valve Code Designations on the last page

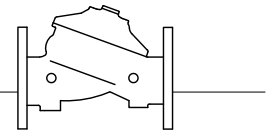

## System Installation

A typical installation of the BERMAD model 42T features a pilot valve for the automatic stable and accurate reduction of water pressure from a high upstream value to a preset lower downstream value, regardless of fluctuating upstream pressure or flow. A unique actuator design ensures quick and smooth valve action. Installed singly, the 42T provides a standard pressure-reducing system. Installed in parallel, two 42T valves provide high flow rates, redundancy, and zero downtime for maintenance. Installed in series, two 42T valves can provide a two-stage, high reduction in pressure and/or added protection to a reduced-pressure zone. To comply with the requirements outlined in the FM, UL and NFPA standards, a pressure relief valve of at least 1/2" is to be installed on the downstream side of any pressure reducing valve. For sizing the required relief valve for optimal performance see the BERMAD recommendation in the table below.

42T Pressure Reducing Valve Size in. (mm)	1 1/2" (40)	2" (50)	2 1/2" (65)	3" (80)	4" (100)	6" (150)	8" (200)	10" (250)	12" (300)	14" (350)	16" (400)
Recommended Relief valve size, in. (mm)	3/4" (20)	3/4" (20)	3/4" (20)	3/4" (20)	2" (50)	3" (80)	3" (80)	4" (100)	2 x 4" (2x100)	2 x 4" (2x100)	2 x 4" (2x100)

The BERMAD FP-3HC-0 and 43T Pressure Relief valves are ideally suited for this purpose, as shown in the installation illustrations.

### Sprinkler System Pressure Reduction

- Reduces a high, unstable pressure supply to a preset, stable system pressure
- Sets the sprinkler pressure to suit the system design
- For zonal pressure control



### Hose System Pressure Reduction

- Reduces a high/unstable pressure supply to suit fire hose pressure
- Limits fire hose pressure to 7 bar (100 psi) to meet NFPA 14 regulations for maximum allowable hose pressure supply



### Two-Stage Pressure Reduction

- High pressure reduction to a low, preset, stable system pressure (when pressure reduction differential is more than 12 bar/175 psi)
- Backup pressure reducing valve in-line to a master valve to secure pressure zone rating at all times



(for Illustration Only)

## Engineer Specifications

The pressure reducing valve shall maintain a constant, preset, downstream pressure regardless of fluctuating upstream pressure or flow.

The valve shall be UL listed and FM approved, 25 bar / 365 psi rated, line pressure driven and pilot operated. It shall be of the elastomeric-type with a straight-through Y-type body.

The valve shall have an unobstructed flow path with no stem guide or supporting ribs.

Valve actuation shall be accomplished by a single-piece, rolling diaphragm bonded with a rugged radial seal disc.

The diaphragm assembly shall be the only moving part.

Maintenance, inspection or service shall be carried out in-line and without removal of the control trim.

The valve and it's entire control trim shall be supplied pre-assembled and hydraulically tested by a factory certified to ISO 9000 and 9001 standards.

# BERMAD Fire Protection

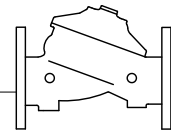

Model FP 400Y - 42T

400Y Series

## Technical Data

### Available Sizes (inch)

- Flanged - 1½, 2, 2½, 3, 4, 6, 8, 10, 12, 14 & 16"
- Grooved - 1½, 2, 2½, 3, 4, 6, 8"
- Threaded - 1½ & 2"

### Pressure Rating

- ANSI#150 - 17.2 bar / 250 psi
- ANSI#300 - 1½, 2 & 2½" 28 bar / 400 psi (\*); 3" to 10" 25 bar / 365 psi 12" to 16" 20 bar / 300 psi
- Grooved: 1½, 2 & 2½" - 28 bar / 400 psi (\*), 3" to 8" 25 bar / 365 psi
- Threaded: 1½ & 2" - 28 bar / 400 psi (\*)
- Setting range: 4 - 12 bar (60 - 175 psi)

\* the 1½, 2 & 2½" valves are UL-Listed for 28 bar/400 psi, and FM Approved for 25 bar/365 psi

### Elastomer

- HTNR - Fabric Reinforced High Temperature Compound - See engineering data

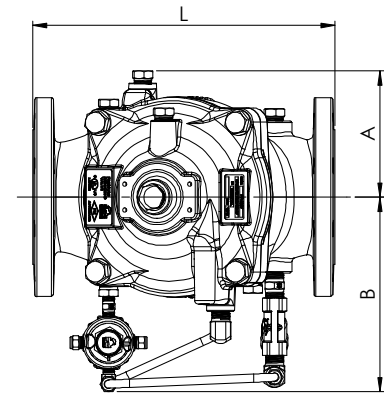
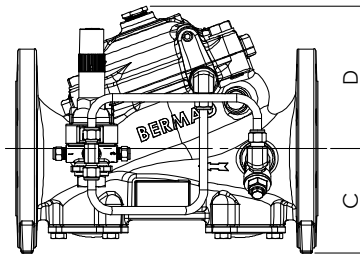

Valve Size	1½" DN40		2" DN50		2½" DN50		3" DN80		4" DN100		6" DN150		8" DN200		10" DN250		12" DN300		14" DN350		16" DN400	
	mm	in	mm	in	mm	in	mm	in	mm	in	mm	in	mm	in	mm	in	mm	in	mm	in	mm	in
L <sup>(1)</sup>	230	9.1	230	9.1	235	9.25	310	12.2	350	13.8	480	18.9	600	23.6	730	28.7	850	33.5	980	38.6	1100	43.3
L <sup>(2)</sup>	230	9.1	238	9.4	241	9.37	326	12.8	368	14.5	506	19.9	626	24.6	730	28.7	888	35	980	38.6	1100	43.3
A	77.5	3	77.5	3	82	3.3	100	3.94	115	4.53	140	5.51	172	6.77	204	8	242	9.53	242	9.53	242	9.53
B	155	6.1	155	6.1	187	7.4	251	9.88	266	10.47	372	14.65	490	19.29	490	19.29	656	25.83	656	25.83	656	25.83
C	64	2.52	77	3.03	92	3.62	106	4.17	121	4.76	140	5.51	172	6.77	204	8.03	247	9.72	272	10.71	316	12.44
D	146	5.8	146	5.8	146	5.8	146	5.75	158	6.22	228	9	295	11.65	296	11.65	441	17.36	441	17.36	415	16.3
Kv / Cv <sup>(4)</sup>	68 / 79		80 / 92		105 / 121		190 / 219		345 / 398		790 / 912		1160 / 1340		1355 / 1565		2370 / 2737		2850 / 3292		3254 / 3758	
Leq <sup>(3)</sup> : m/ft	2 / 7		4 / 14		9 / 31		7 / 23		9 / 30		15 / 49		27 / 89		62 / 203		52 / 171		59 / 194		88 / 289	
Kg/lb flanged#150/ISO16	17.9 / 39.4		19.3 / 42.5		23 / 50		34 / 74.8		44 / 95.8		87.3 / 192		150 / 331		180 / 397		323 / 712		356 / 784		403 / 886	

Notes: <sup>(1)</sup> Refers to the length dimensions for Raised Face ANSI #150, ISO 16 Flanged, Threaded and Grooved valves

<sup>(2)</sup> Refers to the length dimensions for Raised Face ANSI #300 and ISO 25 Flanged valves

<sup>(3)</sup> Leq (Equivalent Pipe Length) refers to a fully opened valve with turbulent flow in new steel pipe schedule 40, values given for general consideration only

<sup>(4)</sup> Kv/Cv values given for a fully opened valve

<sup>(5)</sup> Exact dimensions for the trim envelope may vary with specific component positioning

## Valve Code Designations

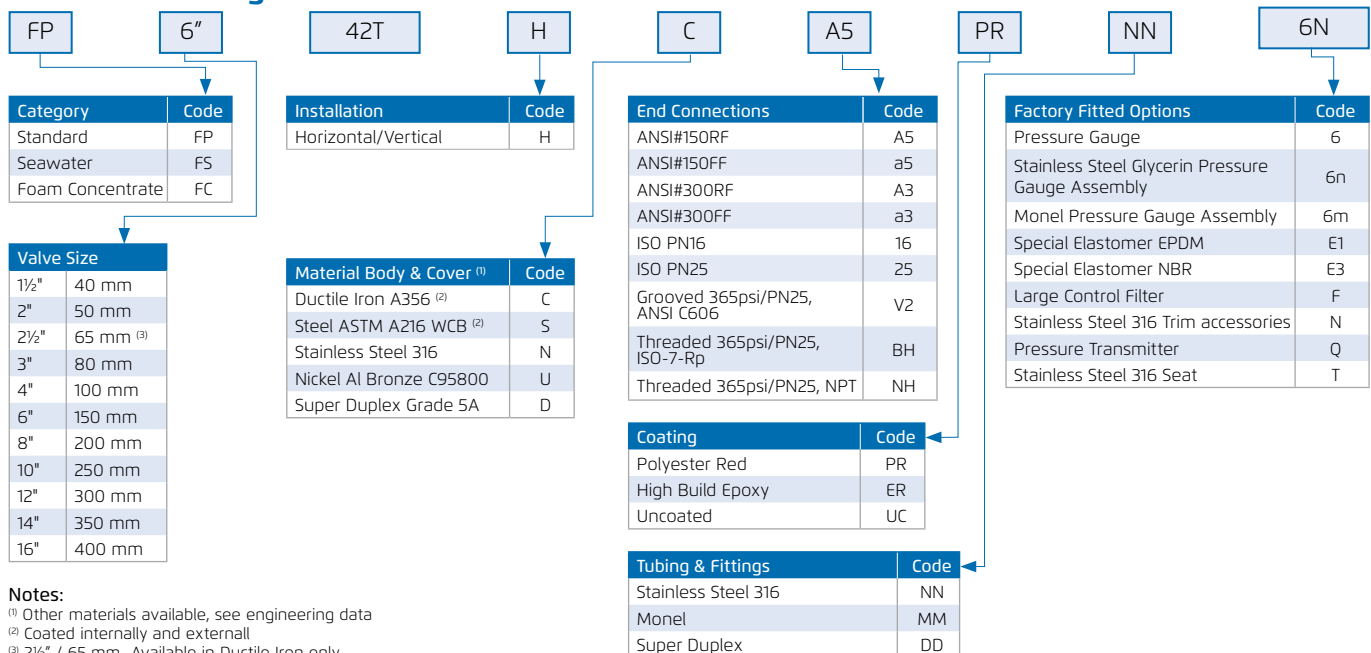

### Notes:

<sup>(1)</sup> Other materials available, see engineering data

<sup>(2)</sup> Coated internally and external

<sup>(3)</sup> 2½" / 65 mm Available in Ductile Iron only



www.bermad.com

© Copyright 2009-2019 Bermad CS Ltd. All Rights Reserved. The information contained in this document is subject to change without notice. BERMAD shall not be liable for any errors contained herein. October 2019